

16.

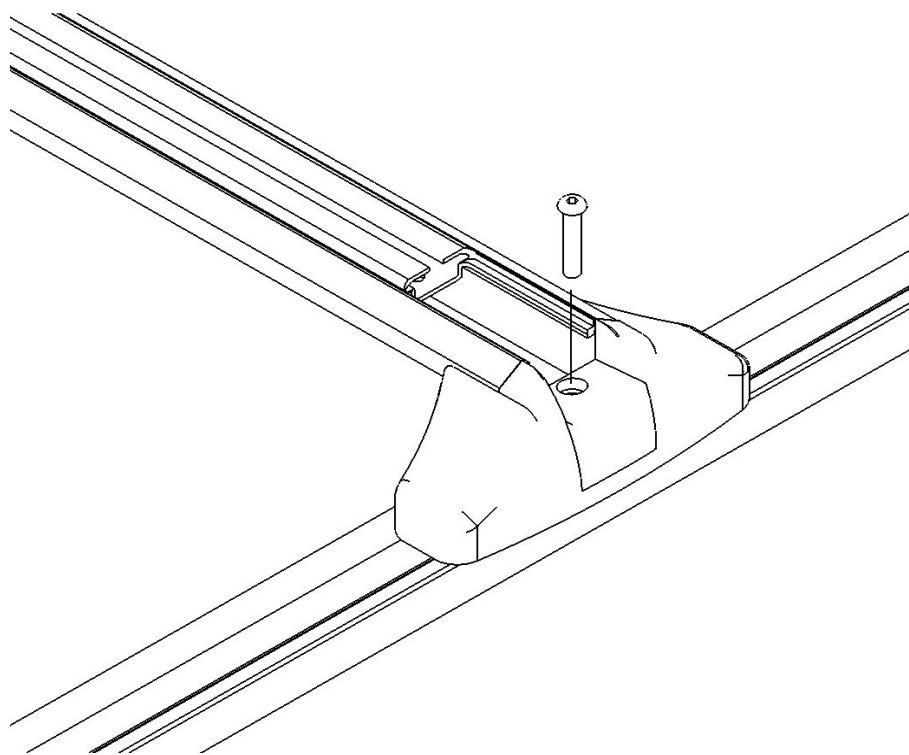

Insert the 1/4-20x 1-1/4" button head screw through the crossbar foot into the rack anchor and tighten with the hex key.

Place the crossbar end cap into the crossbar and tighten the 1/4-20 narrow shoulder screw with the hex key.



Package Contents:

- (4) U-clips
- (4) Sliding Rack Anchors
- (2) Roof Tracks
- (2) Track Bottom Gaskets
- (2) Track Top Covers
- (4) Track End Caps
- (12) 1/4-20 X 1-1/2" Button Head Screws
- (12) Flanged Washers
- (12) Cap Covers
- (12) 1/4-20 Nuts with Integral Lock Washers
- (6) Sliding Tie Downs
- (1) 3oz Tube of Silicon Sealant

Note: For proper width placement of tracks, an optional crossbar template rack crossbar kit should be used for installation.

1

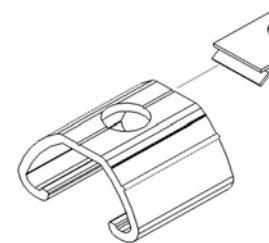

Attach the U-clips to the four sliding rack anchors.

2.

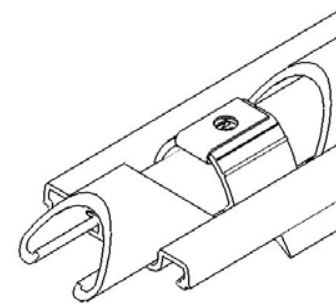

Slide the three sliding tie downs and tighten them onto the track, alternating tie downs across the track.

PRO RAC GUIDELINES

Please review the instructions and warranty carefully. Assembly and installation are the purchaser's responsibility and beyond ProRac's control. Therefore, ProRac exclusively limits its warranty to the repair or replacement of a defective ProRac product for up to three years from retail purchase. Warranty excludes damage to your vehicle, cargo, or any person or property during assembly, installation, and use.

- ◆ Do not carry more than 150 pounds (68KG) of combined cargo and accessories on ProRac crossbars. ProRac crossbars do not increase gutter or roof strength. ProRac cannot warranty loads that exceed this limit.
- ◆ Do not use ProRac crossbars and accessories for purposes other than those for which they were designed. Do not exceed their carrying capacity. Failure to follow these guidelines or the product instructions will void the warranty.
- ◆ Make sure all knobs, bolts, screws, straps, and locks are firmly attached, tightened, and locked before every trip. All fasteners must be periodically inspected for signs of wear, corrosion, and fatigue. Check your load at stops during long trips to ensure continued fastening security.
- ◆ Check all local and state laws governing projection of objects beyond the width and length of vehicle. Be aware of the width and height of your cargo since low-clearance branches, bridges, and parking garages can affect the load. Never drive with any lock, knob, or rack in an open or unlocked position. All long loads such as, but not limited to, sailboards, surfboards, kayaks, canoes, and lumber must be tied down front and rear to the bumpers or tow hooks of the vehicle.
- ◆ Remove your rack and accessories when they are not in use and before entering automatic car washes.
- ◆ All locks must be turned and moved periodically to ensure smooth operation. Use graphite or similar dry lubricant. Locks are designed to deter vandalism and theft. Remove valuable gear if your vehicle is unattended. Replacement keys are available only through your ProRac dealer.
- ◆ All cargo will affect the vehicle's driving behavior. For your safety, adapt your speed to the conditions of the road and load being carried. Obey all posted speed limits and traffic cautions.
- ◆ Due to their wind resistance, do not carry disks or wheels with covers on the ProRac bike carrier.
- ◆ Consult your ProRac dealer if you have questions regarding the operation and limits of ProRac products. Review all instructions and warranty information carefully.

© 2006 ProRac Systems, Inc.

Revised 6-16-06
FGPI1001-IS

ProRac Systems Inc.
7109 31st Avenue North
Minneapolis, MN 55427-2848

Toll Free: 1-800-217-7133
Phone: 763-546-5620
Fax: 763-546-0933
WWW.PRORAC.COM

ProRac Systems Inc.
7109 31st Avenue North
Minneapolis, MN 55427-2848

4.

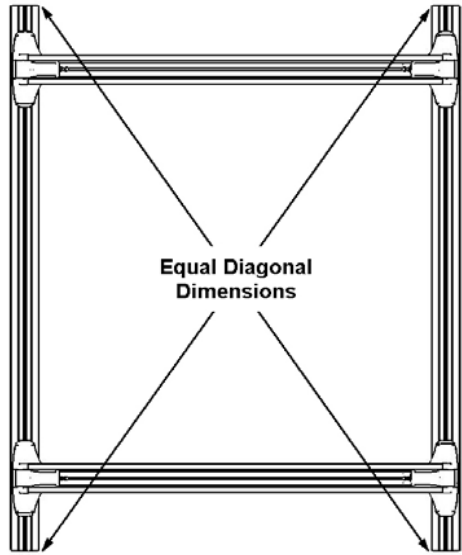

Ensure that the assembly is square by taking diagonal measurements from corner to corner.

When the measurements are equal, fully tighten the crossbars to the tracks.

Place the assembly on the roof and position using the suggested dimensions in step 5.

5. Suggested Dimensions "A"

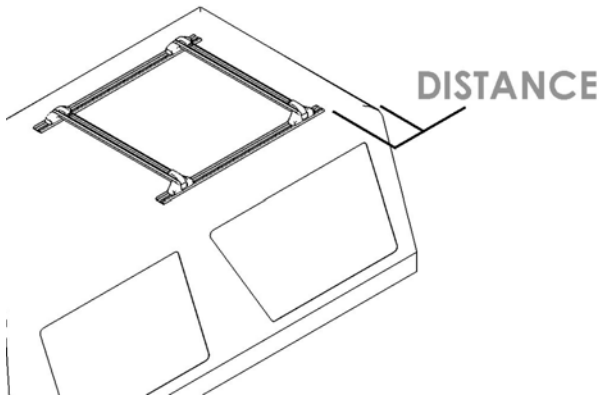

Distance from rear of vehicle to tracks:
 Full Size Van 8" – 10"
 Full Size Sport Utility 4" – 6"
 Mini Van 2" – 4"
 Small Sport Utility 2" – 4"
 Truck Cap 8" -10" or centered

6.

Lift up the edges of the top gasket to reveal the corner holes.

Mark the center of the four corner holes using a center punch.

Remove assembly from the roof.

Remove crossbars from tracks.

7.

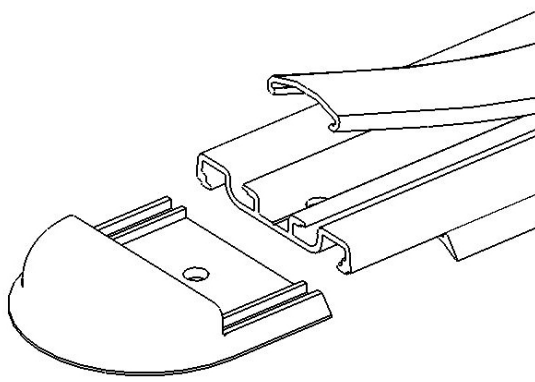

Center the bottom gasket on each track by sliding the end caps into the ends of the track.

8.

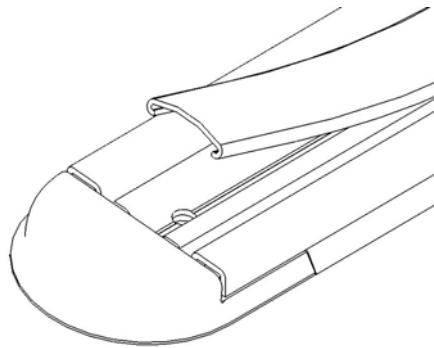

Temporarily secure the end caps to the track with tape. Lift the edges of the top gasket enough to reveal both corner holes.

Reposition the track on the roof, centering the center punch marks with the corner holes.

9.

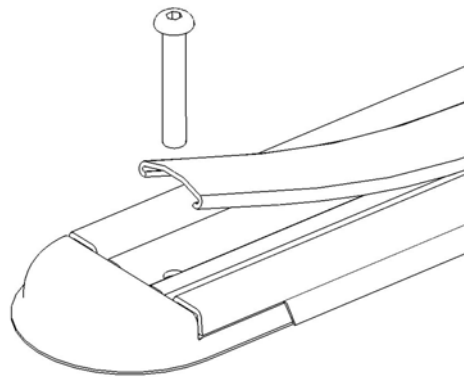

Using the corner hole as a guide, drill a 1/4" diameter hole through the roof. Slide the 1/4-20 x 1-1/2" screw through the hole.

Recheck the position of the other corner hole over the center punch mark. Reposition if needed.

Using the other corner hole as a guide, drill a 1/4" diameter hole through the roof and place the 1/4-20 x 1-1/2" screw through.

10.

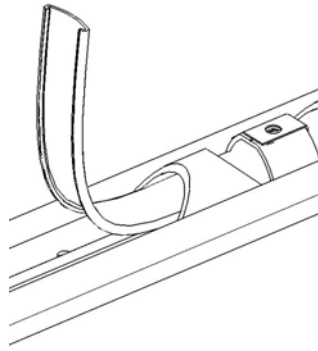

Slide the rack anchors and tie downs to the roof.

Lift the top cover gasket on one end of the track to reveal the rack anchors and tie downs.

Adjust the rack anchor and tie downs so they are centered over the mounting holes.

Lift up the other end of the top cover gasket. This should give access to all mounting holes.

Using the remaining mounting holes as guides, drill 1/4" diameter holes through the roof.

Repeat for other track.

11.

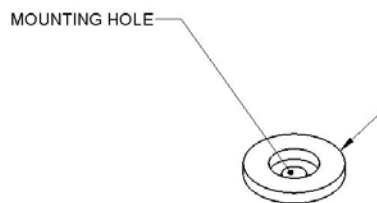

Remove the tracks from the roof.

Clean any debris from drilling the holes.

Place a bead of silicone around each hole. A bead of 1 inch in diameter (25mm), 1/8" in width should be sufficient to seal the hole.

12.

Place two 1/4-20 x 1-1/2" screws through the roof.

Using the two screws as guides, position the track and secured end caps over mounting holes.

Place the track onto the roof.