



Permanent Mount Rack Installation Instructions with Expansion Nuts

Package Contents:

- (1) Hex Key
- (4) Mounting Brackets
- (4) U- Clips
- (4) Permanent Mount Pads
- (4) ¼-20 x 1-1/2" Hex Head Screw
- (4) ¼-20 x 9/16" Narrow Shoulder Button Head Screws
- (8) 10-32 x 1" Screws
- (8) 10-32 Expansion Nuts

1.

Position front and rear crossbars on roof of vehicle.

Recommended center to center spacing of crossbars is 35" when using ProRac accessories.

Place masking tape on roof directly under each rack foot.

Outline base of each foot on tape using marker or pen.

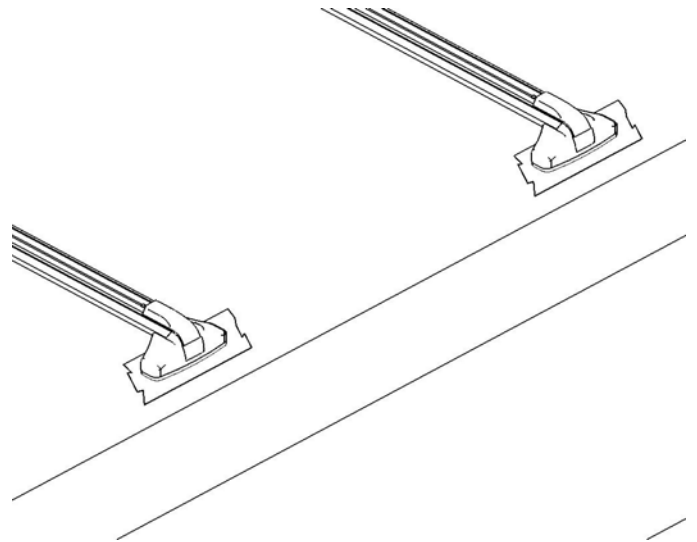

2.

Cut out foot template (see attached page) and place on each outline.

Place a mounting bracket in the center cutout and mark the two screw locations, diagonally across from each other, with a center punch.

Repeat four times.

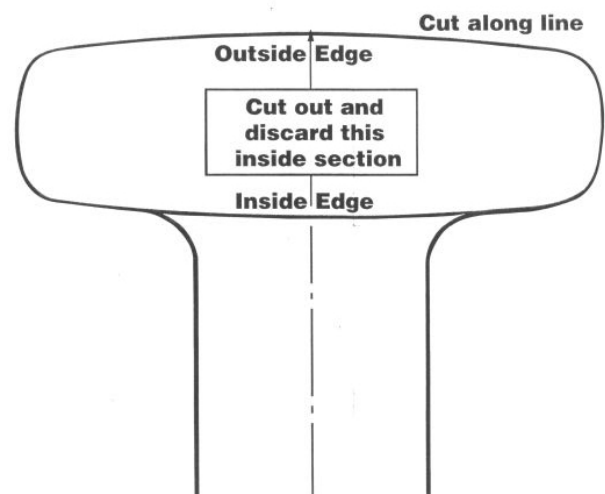

3.

Mount four brackets to roof using the expansion nuts.

Drill .375 dia. Holes, .75 in. deep. **Caution: Do not drill deeper than .75 inches.**

Remove tape. Press rubber nuts into the holes and place brackets over the nuts.

Putting pressure on the screw, screw into the nut until tight.

Attach U-Clip to each bracket. ⚠ Make certain that the U-clip is oriented as shown!!!

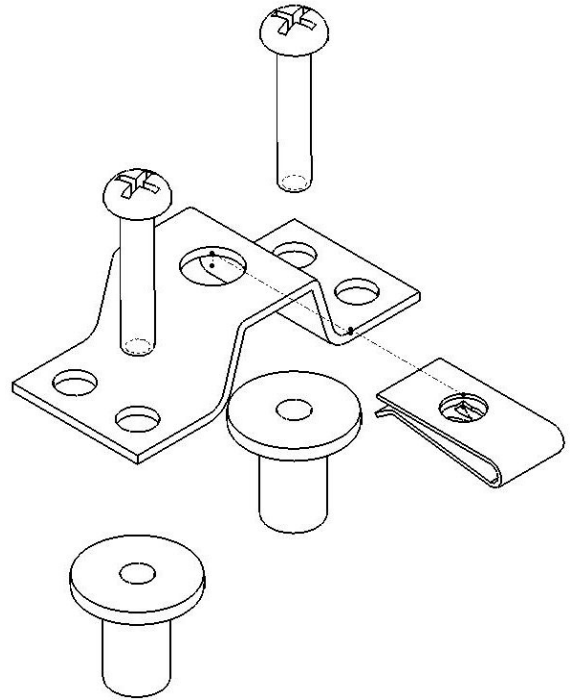

4.

Snap permanent mount pads into each crossbar foot.

Remove crossbar end caps and place cross bars on brackets.

Attach with ¼-20 x 1-1/2" hex head screws and tighten with hex key.

Reinstall end caps to crossbars and secure with ¼-20 narrow shoulder 9/16" screws.

Store hex key in convenient location.

Installation is complete.

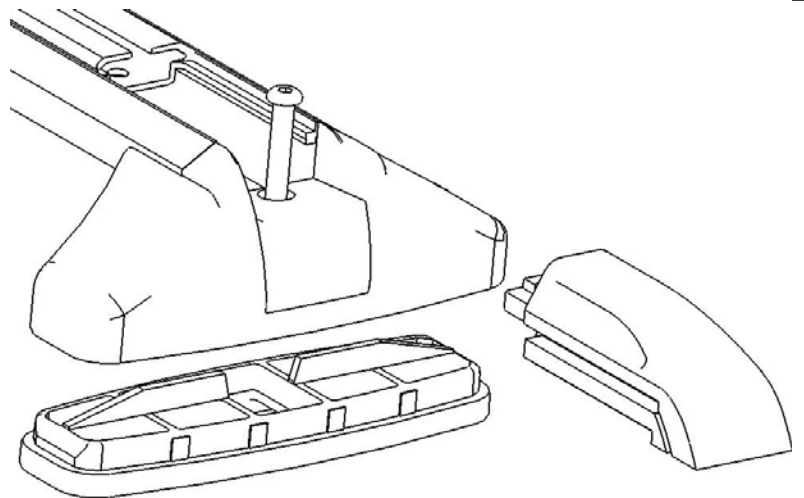

EuroVan Rack Mounting Specifications

5.

Position the front and rear crossbars on the roof using the following procedure.

The rear crossbar should be placed 11 inches from the back roof edge.

The front crossbar should be spaced 35 inches from the rear crossbar.

Note that both location dimensions are to the center mounting holes of the crossbars.

The crossbars should also be centered from side to side on the roof.

Complete installation by following steps 1 through 4 on the installation sheet for Permanent Mount Rack with Expansion Nuts.

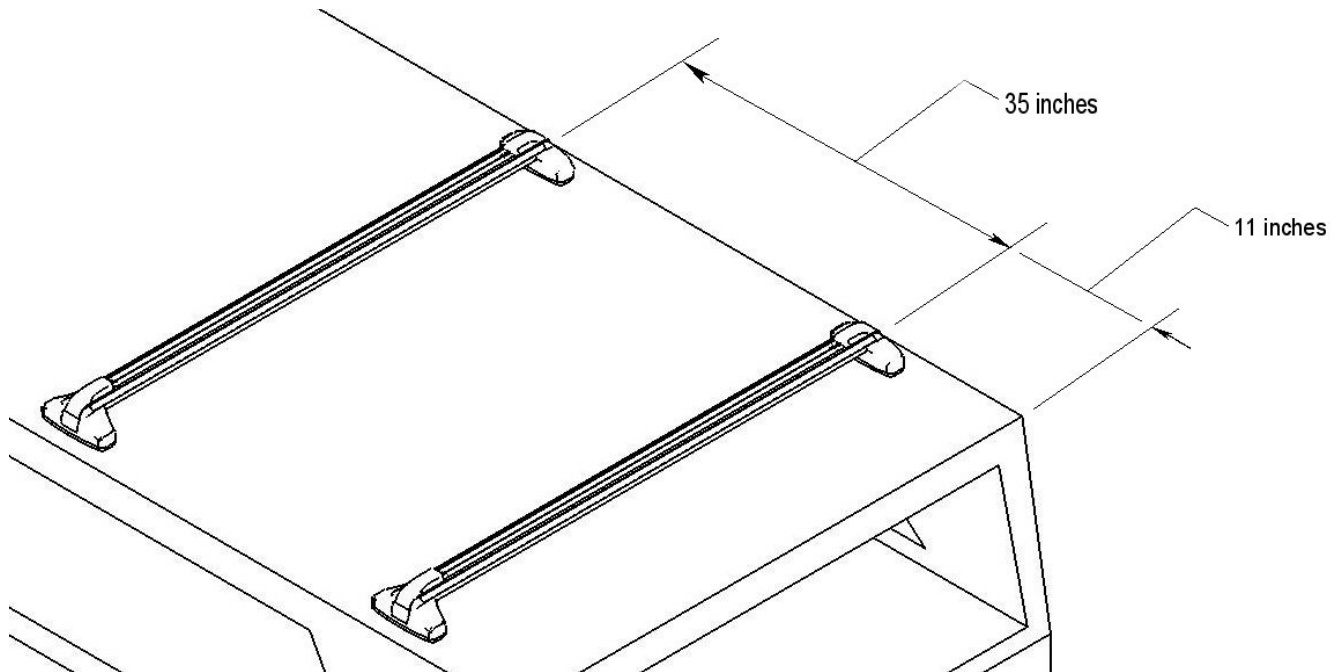

PRO RAC GUIDELINES

Please review the instructions and warranty carefully. Assembly and installation are the purchaser's responsibility and beyond ProRac's control. Therefore, ProRac exclusively limits its warranty to the repair or replacement of a defective ProRac product for up to three years from retail purchase. Warranty excludes damage to your vehicle, cargo, or any person or property during assembly, installation, and use.

- ◆ Do not carry more than 150 pounds (68KG) of combined cargo and accessories on ProRac crossbars. ProRac crossbars do not increase gutter or roof strength. ProRac cannot warranty loads that exceed this limit.
- ◆ Do not use ProRac crossbars and accessories for purposes other than those for which they were designed. Do not exceed their carrying capacity. Failure to follow these guidelines or the product instructions will void the warranty.
- ◆ Make sure all knobs, bolts, screws, straps, and locks are firmly attached, tightened, and locked before every trip. All fasteners must be periodically inspected for signs of wear, corrosion, and fatigue. Check your load at stops during long trips to ensure continued fastening security.
- ◆ Check all local and state laws governing projection of objects beyond the width and length of vehicle. Be aware of the width and height of your cargo since low-clearance branches, bridges, and parking garages can affect the load. Never drive with any lock, knob, or rack in an open or unlocked position. All long loads such as, but not limited to, sailboards, surfboards, kayaks, canoes, and lumber must be tied down front and rear to the bumpers or tow hooks of the vehicle.
- ◆ Remove your rack and accessories when they are not in use and before entering automatic car washes.
- ◆ All locks must be turned and moved periodically to ensure smooth operation. Use graphite or similar dry lubricant. Locks are designed to deter vandalism and theft. Remove valuable gear if your vehicle is unattended. Replacement keys are available only through your ProRac dealer.
- ◆ All cargo will affect the vehicle's driving behavior. For your safety, adapt your speed to the conditions of the road and load being carried. Obey all posted speed limits and traffic cautions.
- ◆ Due to their wind resistance, do not carry disks or wheels with covers on the ProRac bike carrier.
- ◆ Consult your ProRac dealer if you have questions regarding the operation and limits of ProRac products. Review all instructions and warranty information carefully.

© 2006 ProRac Systems, Inc.

SAH303-8I
Revised 06-14-06

